

Customer reference case

Off-road vehicles

Kingpin in steering systems

SKF TX spherical plain bearings
and PTFE coated seals



Self-lubricating bearings and seals promote Case New Holland's hi-tech steering system

Tractors, like many other off-road vehicles, are rapidly taking advantage of the boom in technology. Today, some tractors are equipped with electronic steering modules so that steering can be controlled by a global positioning system (GPS).

As steering systems incorporate more electronics, positioning sensors are needed to provide the angle of the wheels by measuring the position of the kingpin. With this data, the central processing unit can adjust critical parameters like steering feedback and the number of turns lock-to-lock. Depending on the system's design, and the design of the sensor, the operating environment of the bearing and sensor has to be free of contaminants and free of any lubricants. Otherwise, they could interfere with the sensor.

This initially posed a problem for Case New Holland. They needed a lubricant-free solution that could accommodate high static and dynamic loads and occasional shock loads and that could also exclude contaminants like dirt and water, which pose a constant threat to bearing and seal service life, especially around the kingpin. SKF applications engineers recommended the SKF TX self-lubricating spherical plain bearing and a new PTFE coated seal. This bearing and seal combination proved to be highly effective.

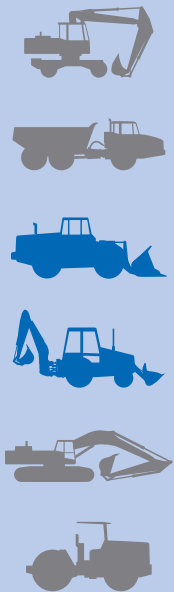

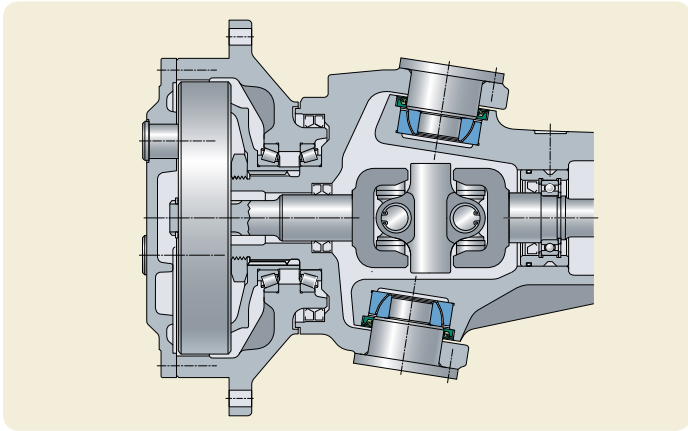

**Kingpin arrangement
in a tractor**

Customer benefits

- ✓ Eliminates need for lubricant
- ✓ Eliminates grease fittings
- ✓ Increases MTBF
- ✓ Environmentally friendly
- ✓ Reduces warranty claims
- ✓ Improves sensor reliability

About the solution

When a TX spherical plain bearing is used in conjunction with the new SKF PTFE coated seal, there are a number of benefits. First and most important to the customer was that the TX spherical plain bearing and the seal could work effectively without any lubricant. This is particularly important for the seal, as most seals require either grease or oil to reduce friction and prevent the ingress of contaminants. The ability of the bearing and seal to slide easily is also important in this application.

The SKF PTFE liner is what gives the TX bearing its performance characteristics. The structure of this self-lubricating fabric, the resin and the bonding agent make TX bearings stronger than previous or competitive designs. Benefits of TX spherical plain bearings include:

- high degree of stiffness, resulting in less deformation under load,
- better wear-resistance and increased service life,
- excellent sliding properties for reduced friction,
- low affinity to moisture for longer service life.



Bearing and seal kits

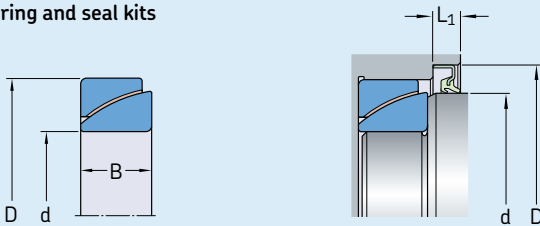

Bearing			Seal			Kit designation
d	D	B	d	D	L ₁	
mm			mm			–
30,162	64,292	21,431	56	70	10	LK-BPV-0152
40	80	24,75	70	90	10	LK-BPV-0153

Additional sizes are available on request.

SKF is a registered trademark of the SKF Group.

© SKF Group 2006
The contents of this publication are the copyright of the publisher and may not be reproduced (even extracts) unless permission is granted. Every care has been taken to ensure the accuracy of the information contained in this publication but no liability can be accepted for any loss or damage whether direct, indirect or consequential arising out of the use of the information contained herein.

Publication **6273 EN**

Printed in Sweden.

